

1/2" Heavy Duty Hydraulic Regulator

Series 20313

Technical Drawings

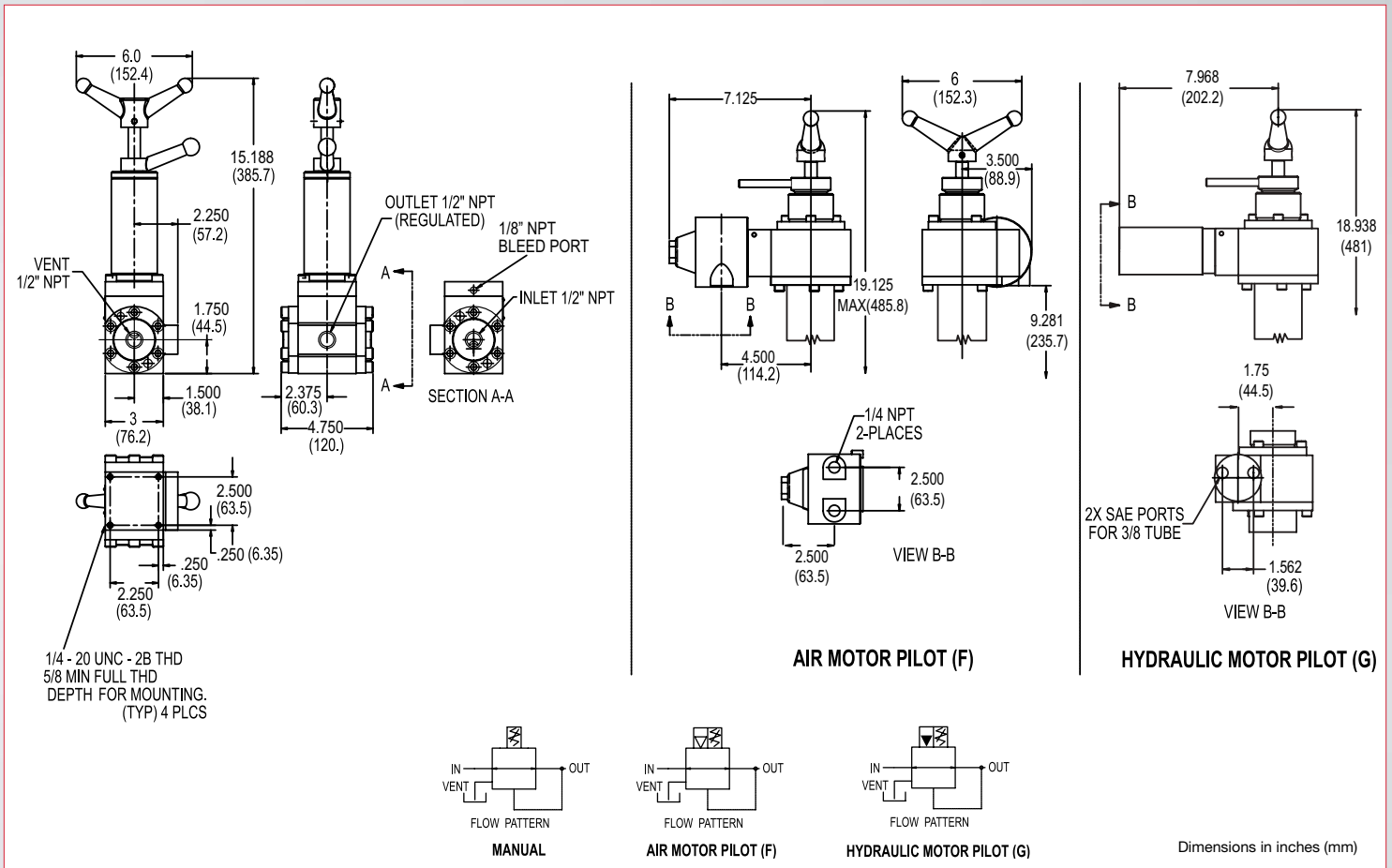

Product Configurator

Example:

20313S6WQ2

Option

Blank	NPT porting
-MS	SAE porting

Adjustment Method

Blank	Manual
F	Pneumatic motor
G	Hydraulic motor

Regulated Pressure Range

Blank	High sensitivity	300 - 1600 psi (21 - 110 bar)
-1	Full range	300 - 3000 psi (21 - 207 bar)

Series

20313S6WQ2 1/2" Shear-Seal Regulator